

HARRINGTON TNER SERIES THEATRICAL CHAIN HOISTS

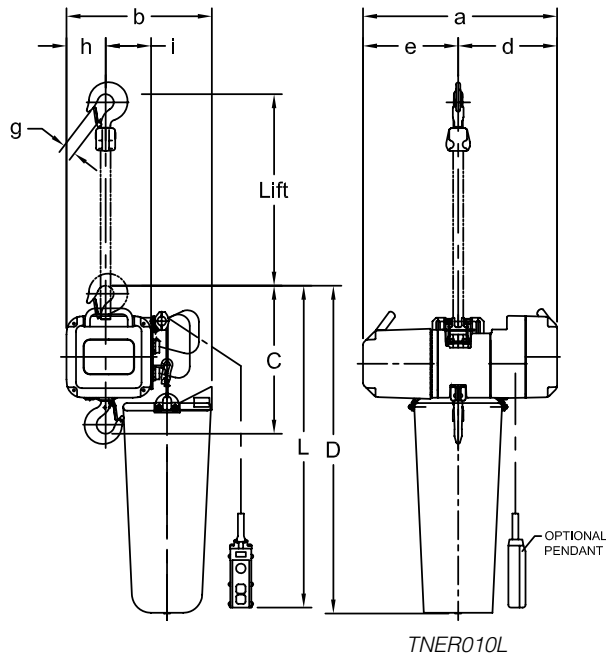

TNER010L



TNER010L

SINGLE SPEED—SPECIFICATIONS

Capacity (Tons)	Product Code	Standard Lift (ft)	Standard Push Button Cord L* (ft)	Lifting Speed (ft/min)	Lifting Motor 3 Phase 60 Hz			Load Chain Diameter (mm) x Chain Fall Lines	Net Weight for 10' Lift (lbs)	Net Weight for 60' Lift (lbs)	Weight for Additional One Foot of Lift (lbs)
					Output (Hp)	Rated Current (amps)					
						@208 - 230V	@460V				
1/2	TNER005L	10' or 60'	2.5	16	0.65	3.7	1.8	6.3 x 1	73	99	0.57
1	TNER010L				1.3	5.6	2.8	8.0 x 1	88	135	0.93
2	TNER020L			8			8.0 x 2	117	209	1.9	

*Pendant (pickle) is optional.

SINGLE SPEED—DIMENSIONS

Capacity (Tons)	Product Code	Headroom C (in)	a (in)	b (in)	d (in)	e (in)	g (in)	h (in)	i (in)	D (in)
1/2	TNER005L	13.2	18.7	14.2	9.6	9.2	0.9	3.9	4.0	35.4
1	TNER010L	16.1	20.0	15.0	10.2	9.8	1.2	4.1	4.7	37.0
2	TNER020L	22.8					1.6			48.8